

GENERAL NOTES:- 1. DO NOT MANUFACTURE FROM THIS DRAWING / SPEC. UNLESS THE CONTROL STAMP IS **RED**. 2. THE DRAWING AND DESIGN IS THE PROPERTY OF P C COX LIMITED. THE CONTENTS HEREIN MUST NOT BE USED, COPIED OR DISCLOSED TO ANY THIRD PARTY WITHOUT THE COMPANY'S WRITTEN CONSENT. 3. P C COX LIMITED RESERVE THE RIGHT TO AMEND THE DESIGN AND SPECIFICATION OF THIS PRODUCT WITHOUT PRIOR NOTICE.

STOCK No: Barth Spreader

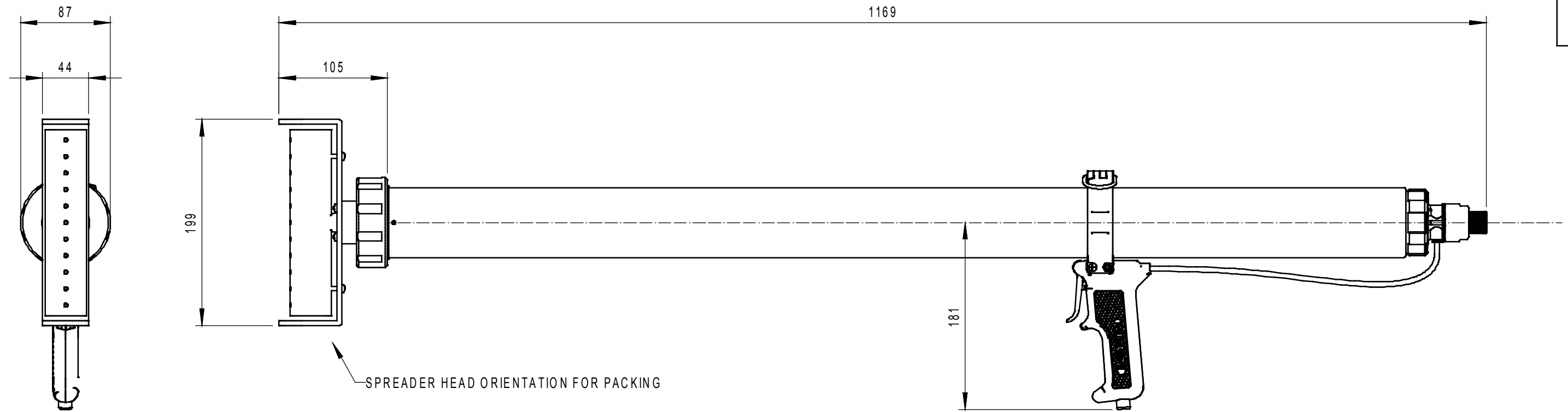

				MODEL TYPE	AM8541	
				DESCRIPTION	BARTH FLOOR SPEADER	
				FINISH		
				STOCK No.	Barth Spreader	
				MATERIAL		
				TOLERANCE		
				CHECK	DIMS mm	SCALE
				DRAWN	cliffordbeckett	DATE 06/01/2010

P C COX LIMITED
 TURNPIKE INDUSTRIAL ESTATE
 NEWBURY
 BERKSHIRE
 RG14 2LR
 ENGLAND
 TEL: 01635 264500
 FAX: 01635 264555
 www.pccox.co.uk



Quality Sealant Applicators

PCC GAUGE No. -	REV	DESCRIPTION	DATE	SIG
-----------------	-----	-------------	------	-----

Parts List		
STOCK No	DESCRIPTION	QTY
2C1403	European Quick Release Fitting	1
2F1734	M4 x 10mm Screw	4
2M2031	Reducer Washer	1
2M2044	Dump Valve Body	1
2N1007	White Cone Nozzle	1
2P1021	Split Sachet Plunger	1
2S2007	O Ring	1
2S2132	Reducer Seal	1
2S2150	Dump Valve Diaphragm	1
2XB054	End Plug	2
3F3005	Cord Retainer Pin	1
3N1038	Barth Nozzle	1
3R4004	Reducer	1
3XS061	Barth Spreader Head	1
3XS062	Barth Spreader Head Bar	1
4B1200	Air Gun Butt Assembly	1
7A1071	Piston/Plunger/Cord Assembly	1
7A1504	Regulator Assembly (Including O-ring and Washer)	1
7B4054	Barrel	1
7C1001	Air Gun Back Cap	1
7C10421	Front Cap	1
7C1043	2.5" 2 Start Cap (38mm dia hole)	1
7XS012	Barrel Strap Assembly (inc screws and nuts)	1

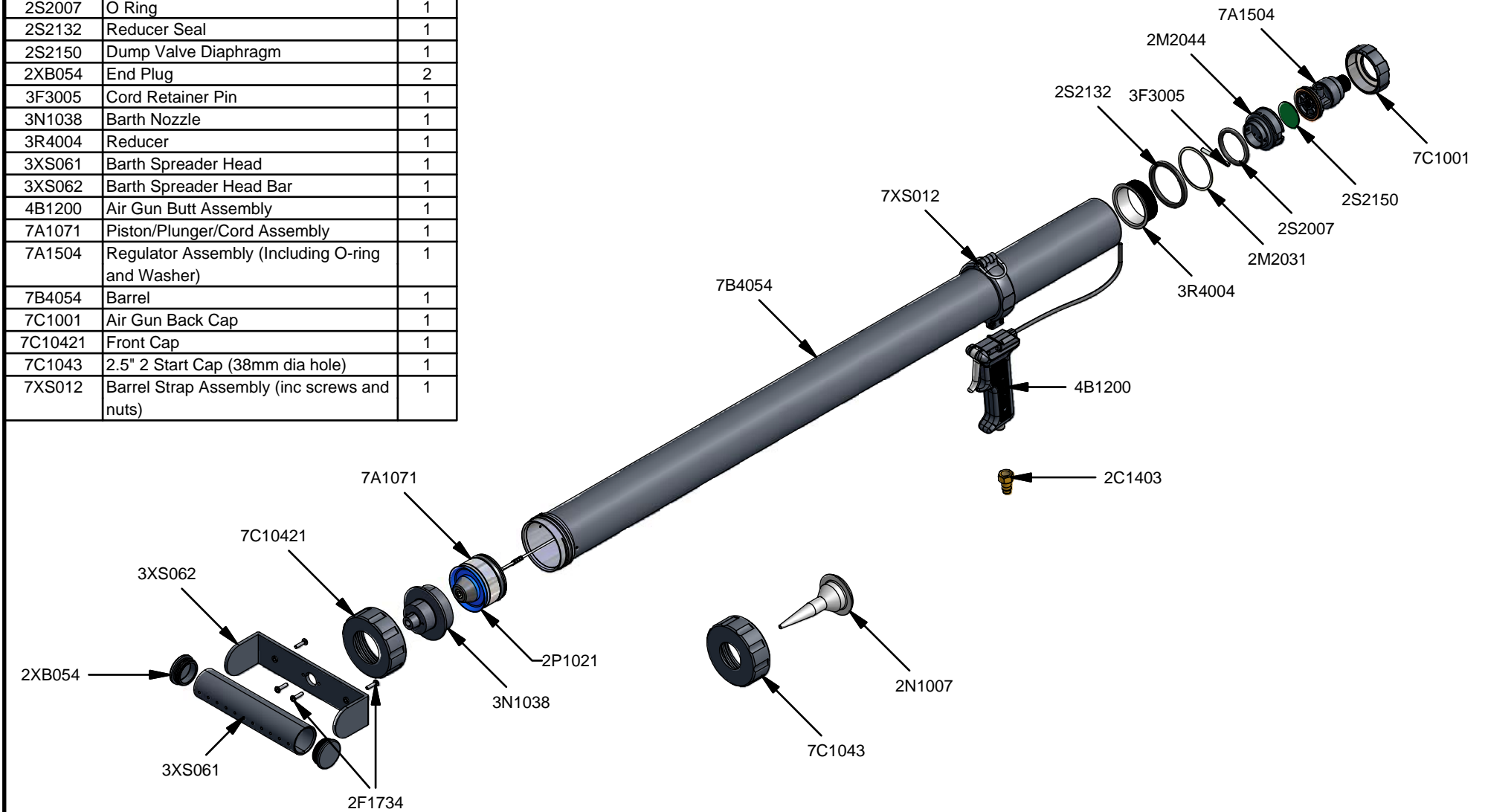

AM8541:Parkett-X-Press AIR 63



www.pccox.co.uk
sales@pccox.co.uk
TEL:44(0)1635 264500

REV
C

DATE
20/07/2010

Parts List		
STOCK No	DESCRIPTION	QTY
2C1403	European Quick Release Fitting	1
2F1734	M4 x 10mm Screw	4
2M2031	Reducer Washer	1
2M2044	Dump Valve Body	1
2N1007	White Cone Nozzle	1
2S2007	O Ring	1
2S2132	Reducer Seal	1
2S2150	Dump Valve Diaphragm	1
2XB054	End Plug	2
3F3005	Cord Retainer Pin	1
3N1038	Barth Nozzle	1
3R4004	Reducer	1
3XS061	Barth Spreader Head	1
3XS062	Barth Spreader Head Bar	1
4B1200	Air Gun Butt Assembly	1
7A1071	Piston/Plunger/Cord Assembly	1
7A1504	Regulator Assembly (Including O-ring and Washer)	1
7B4054	Barrel	1
7C1001	Air Gun Back Cap	1
7C10421	Front Cap	1
7C1043	2.5" 2 Start Cap (38mm dia hole)	1
7XS012	Barrel Strap Assembly (inc screws and nuts)	1

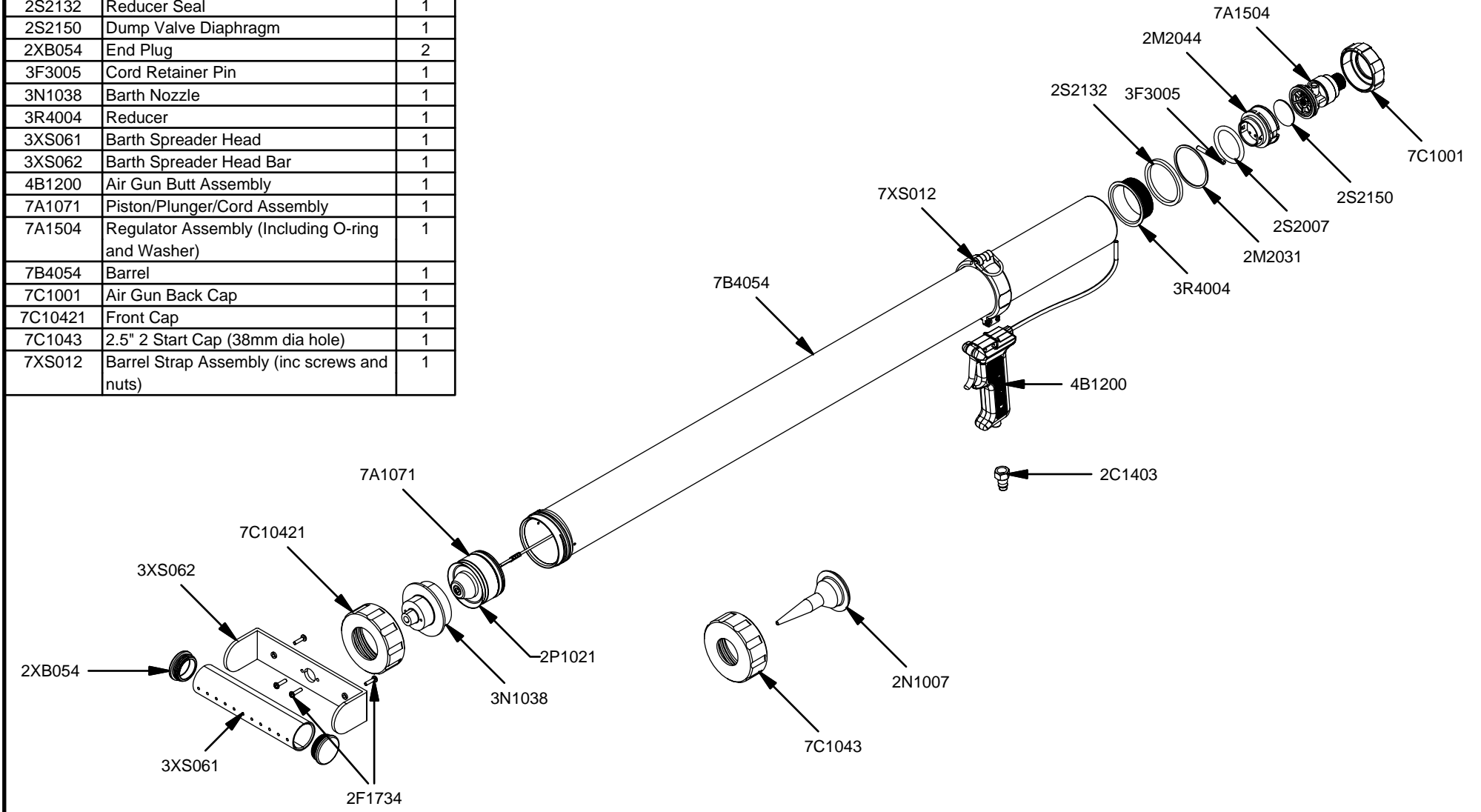

AM8541:Parkett-X-Press AIR 63



www.pccox.co.uk
sales@pccox.co.uk
TEL:44(0)1635 264500

REV	DATE
C	20/07/2010

REV	DATE
C	20/07/2010